

Service and Repair

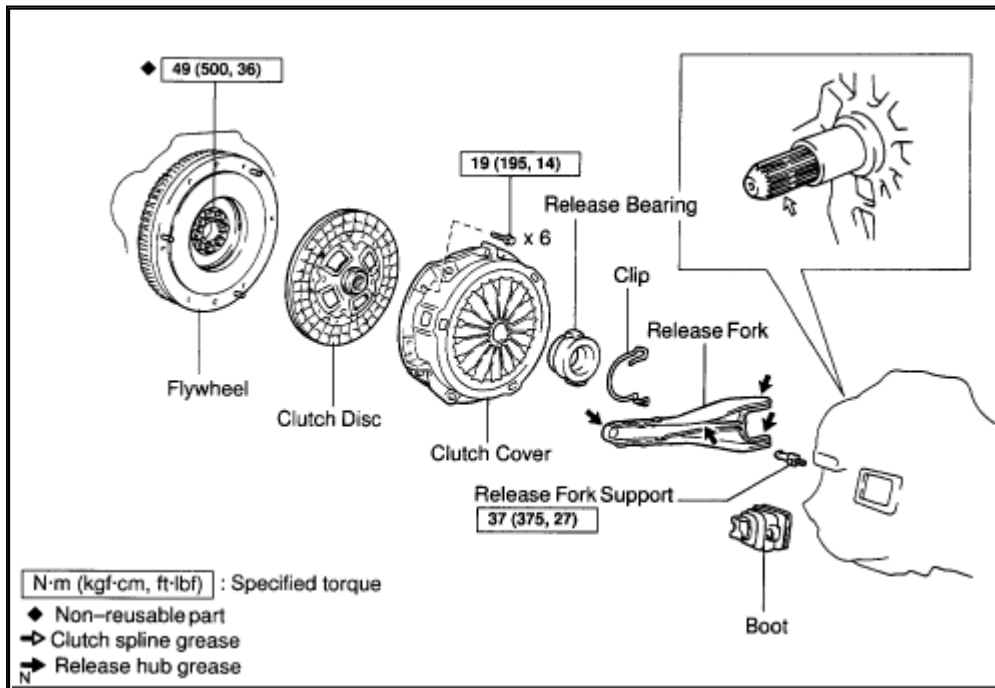

ZOOM

SIZED FOR PRINT

REMOVAL

1. REMOVE TRANSAXLE FROM ENGINE

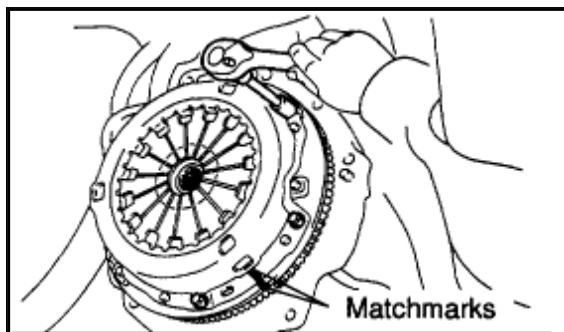

ZOOM

SIZED FOR PRINT

2. REMOVE CLUTCH COVER AND DISC

- a) Align the matchmark on the clutch cover with the one on the [flywheel](#).
- b) Loosen each set bolt one turn at a time until spring tension is released.
- c) Remove the set bolts, and pull off the clutch cover with the [clutch disc](#).

NOTICE: Do not drop the [clutch disc](#).

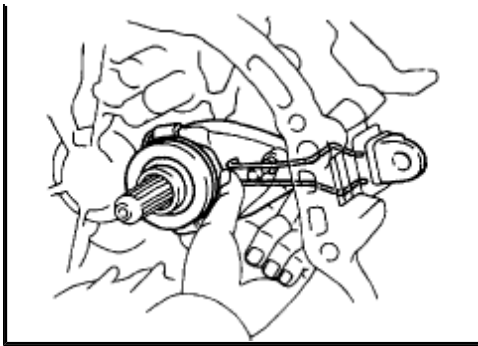

ZOOM

SIZED FOR PRINT

3. REMOVE RELEASE BEARING AND FORK FROM TRANSAXLE Remove the release bearing with the fork together and then separate them.
4. REMOVE RELEASE FORK SUPPORT AND BOOT

INSPECTION

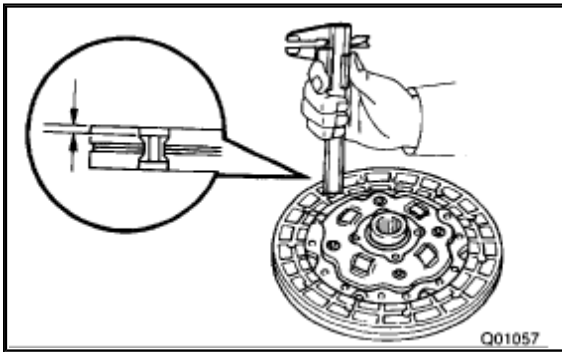

ZOOM

SIZED FOR PRINT

1. INSPECT **CLUTCH DISC** FOR WEAR OR DAMAGE Using vernier calipers, measure the rivet head depth. Minimum rivet depth: **0.3 mm (0.012 inch)** If necessary, replace the **clutch disc**.

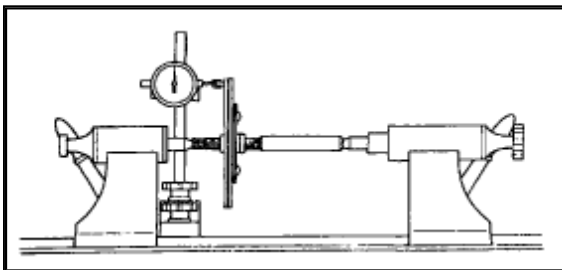

ZOOM

SIZED FOR PRINT

2. INSPECT **CLUTCH DISC** RUNOUT Using a dial indicator, check the disc runout. Maximum runout: **0.8 mm (0.031 inch)** If necessary, replace the **clutch disc** runout.



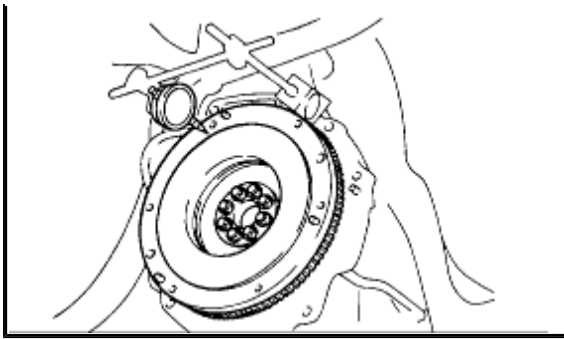

ZOOM

SIZED FOR PRINT

3. INSPECT **FLYWHEEL** RUNOUT Using a dial indicator, check the **flywheel** runout. Maximum runout:**0.1 mm (0.004 inch)** If necessary, replace the **flywheel**. Torque: **49 Nm (500 kgf-cm, 36 ft. lbs.)**

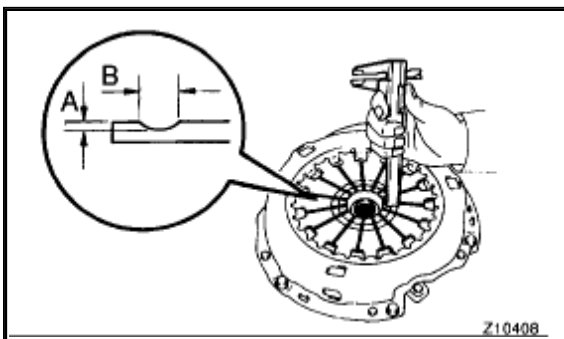

ZOOM

SIZED FOR PRINT

4. INSPECT DIAPHRAGM SPRING FOR WEAR Using vernier calipers, measure the diaphragm spring for depth and width of wear. Maximum: A (Depth): **0.5 mm (0.020 inch)** B (Width): **6.0 mm (0.236 inch)** If necessary, replace the clutch cover.

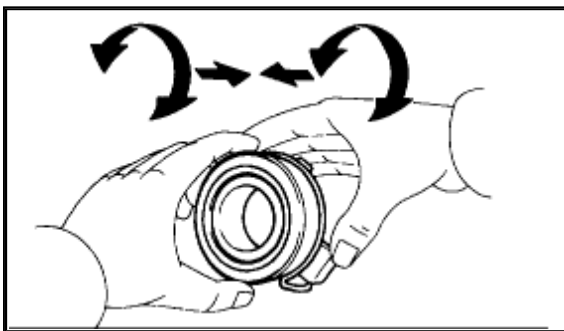

ZOOM

SIZED FOR PRINT

5. INSPECT RELEASE BEARING Turn the bearing by hand while applying force in the axial direction. **HINT:** The bearing is permanently lubricated and requires no cleaning or lubrication. If necessary, replace the release bearing.

INSTALLATION

1. INSTALL **CLUTCH DISC** AND CLUTCH COVER ON **FLYWHEEL**

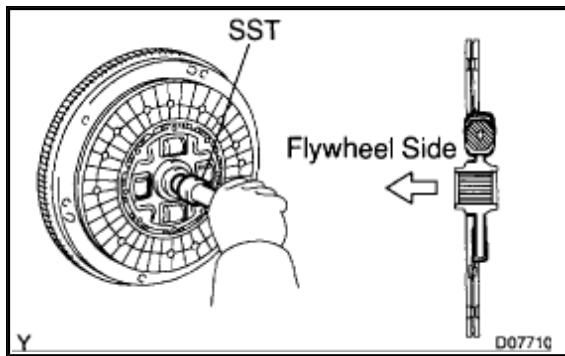

ZOOM SIZED FOR PRINT

- a) Insert SST in the [clutch disc](#), then insert them in the [flywheel](#).
SST 09301-00210

HINT: Take care not to insert [clutch disc](#) in the wrong direction.

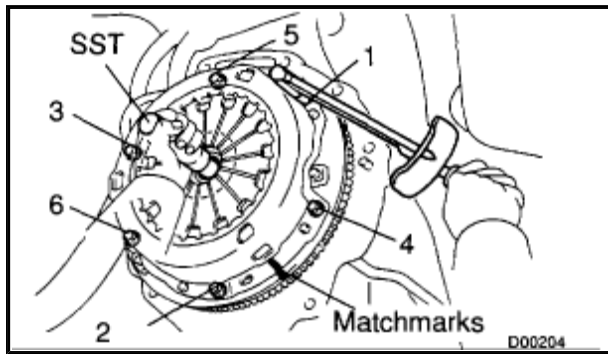

ZOOM SIZED FOR PRINT

- b) Align the matchmarks on the clutch cover and [flywheel](#).
- c) Following the procedures shown in the illustration, tighten the 6 bolts in the order starting the bolt locating near the knock pin on the top.
Torque: **19 Nm (195 kgf-cm, 14 ft. lbs.)**

HINT:

- Following the order in the illustration, tighten the bolts at a time evenly.
- Move SST up and down, right and left lightly, after checking that the disc is in the center, tighten the bolts.



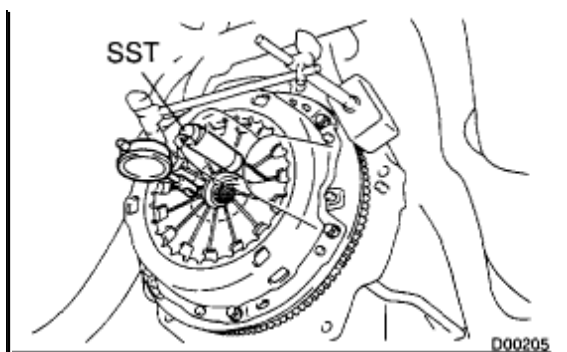

ZOOM

SIZED FOR PRINT

2. **CHECK DIAPHRAGM SPRING TIP ALIGNMENT** Using a dial indicator with roller instrument, check the diaphragm spring tip alignment. Maximum non-alignment: 0.5 mm (0.020 inch) If alignment is not as specified, using SST, adjust the diaphragm spring tip alignment. SST 09333-00013
3. **INSTALL BOOT AND RELEASE FORK SUPPORT TO TRANSAXLE** Torque: 37 Nm (375 kgf-cm, 27 ft. lbs.)

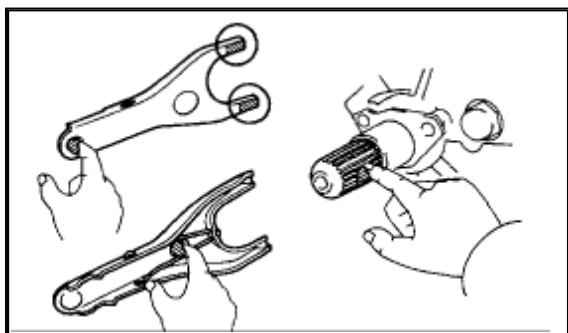

ZOOM

SIZED FOR PRINT

4. **APPLY RELEASE HUB GREASE** Apply release hub grease to the release fork and hub contact, release fork and push rod contact and release fork pivot points. Sealant: Part No. 08887-01806, RELEASE HUB GREASE or equivalent
5. **APPLY CLUTCH SPRING GREASE** Apply **clutch** spline grease to the **input shaft** spline. Sealant: Part No. 08887-01706, **CLUTCH** SPLINE GREASE or equivalent
6. **INSTALL RELEASE BEARING AND FORK TO TRANSAXLE** Install the bearing to the release fork, and then install them to the transaxle.
7. **INSTALL TRANSAXLE TO ENGINE**